



STAINLESS STEEL SCISSORS HIGHLIFTER

This highlifter with high lifting capacity is particularly suitable for fishing, slaughtering and pharmaceutical industries, i.e. for all those places where the requirements in terms of hygiene and health are particularly stringent.

The highlifter is made of stainless steel, thus it can withstand humid or aggressive environments and can be cleaned with strong chemical products. For particularly aggressive environments, the pallet truck can be made of acid-resistant stainless steel.

This electric truck is a good solution in all cases where numerous lifts are required during the working day. Load lowering is controlled by a release handle, which allows the operator to increase the lowering speed at any level. The stainless steel highlifter features stainless steel frame, tiller arm, shafts, pins, moulds and screws. The lifting cylinder, scissors legs and battery compartment are also made of stainless steel.

- ✓ **LOAD CAPACITY UP TO 1.000 KG**
- ✓ **SPECIAL CONSTRUCTIONS UPON REQUEST**
- ✓ **SPECIAL DIMENSIONS UPON REQUEST**

SOME OPTIONALS



USE IN COLD STORE

Type	Stainless steel forklift trucks	Class	Stainless steel manual and semi-electric pallet trucks
Load capacity (Kg)	1000	Lifting capacity (mm)	800

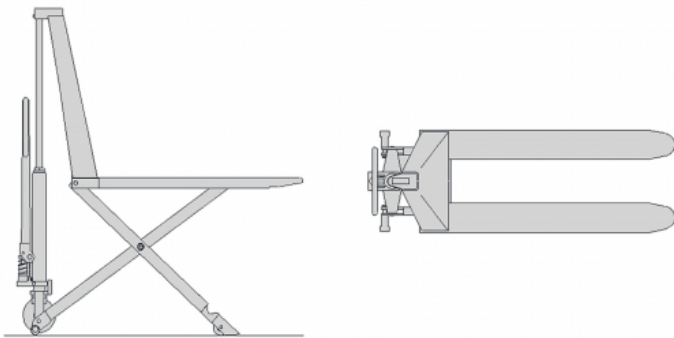

Characteristics

Portata	1000 kg
Outside width	560 mm
Fork length	1200 mm
Height of forks from ground	90 mm
Hydraulic motor	12V / 0,8KW
Lifting speed loaded	0,08 m/sec
Lifting speed unloaded	0,05 m/sec
Battery	1x12 V
Battery capacity	50 Ah / 5h
Battery weight	20 kg
Charger	12 V / 5 A
Lowering speed	Variable
Steering wheels	Nylon
Load wheels	Nylon
Weight without battery	135 kg
Weight with battery	155 kg